



# INSTALLATION INSTRUCTIONS

Accessory  
**HIGH WIND SCREEN**  
P/N 08R70-MKN-D10

Application  
**CBR650RA**

Publication No.  
**MII**  
Issue Date  
**October 2018**

**Honda Dealer: Please give a copy of these instructions to your customer.**

## PARTS LIST

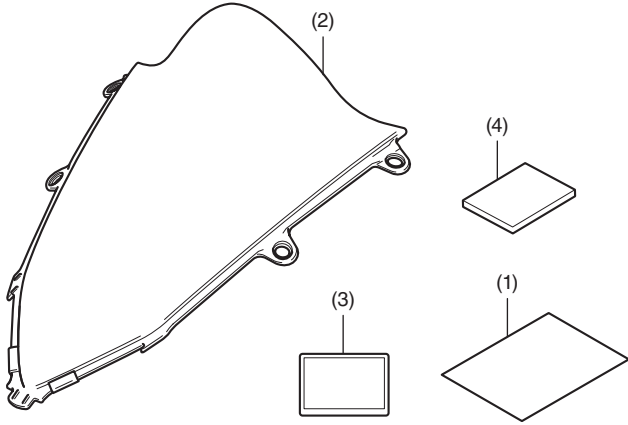

No.	Description	Qty
(1)	URL paper	1
(2)	High wind screen	1
(3)	Label	1
(4)	Aluminium tape	1

## SUPPLIES REQUIRED

- Scale
- Primer
- Synthetic detergent solution  
(Water : Synthetic detergent / 100 : 1)
- Isopropyl alcohol
- Shop towel

## TORQUE CHART

Refer to the Service Manual for the torque values of the removed parts.

## INSTALLATION

### NOTE:

- Heat the bonding surfaces with a hair dryer if the ambient air temperature is below 70°F (21°C).
- The adhesive reaches full strength in 72 hours. Wait at least 24 hours before riding your motorcycle.

- Remove the parts as shown.

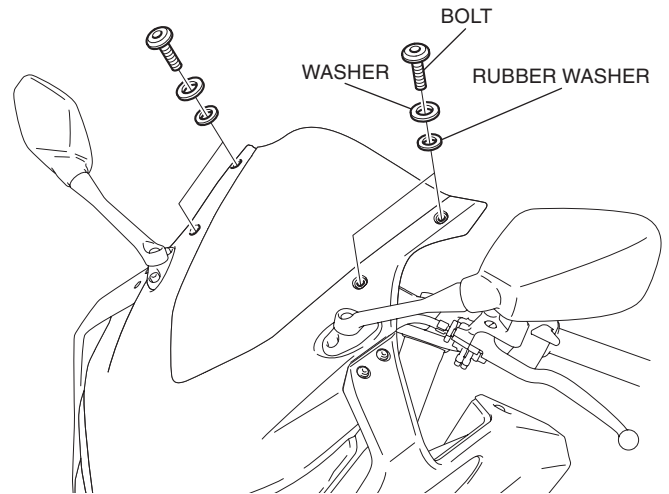

- Remove the wind screen as shown.

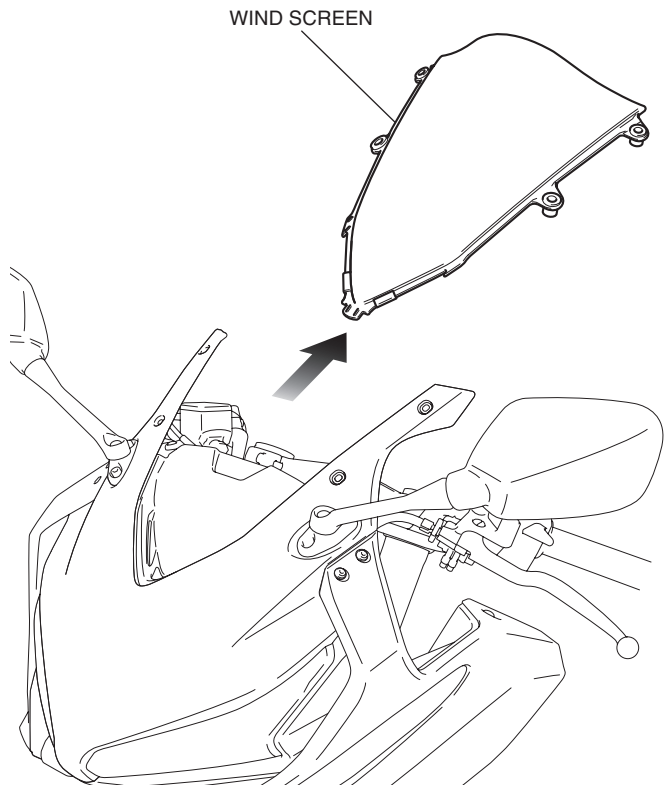

3. Remove the bolts as shown.  
• Repeat on the right side.

<Left side>

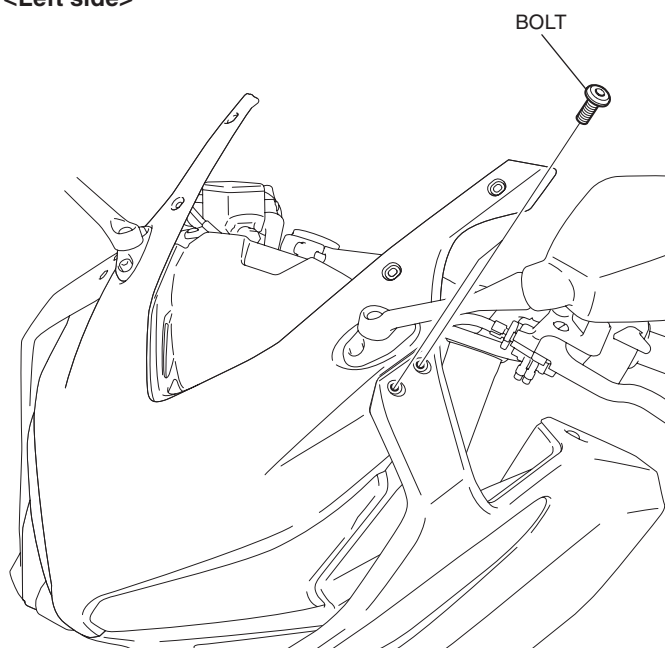

4. Open the left middle cowl as shown and remove the screw.

- Repeat on the right side.

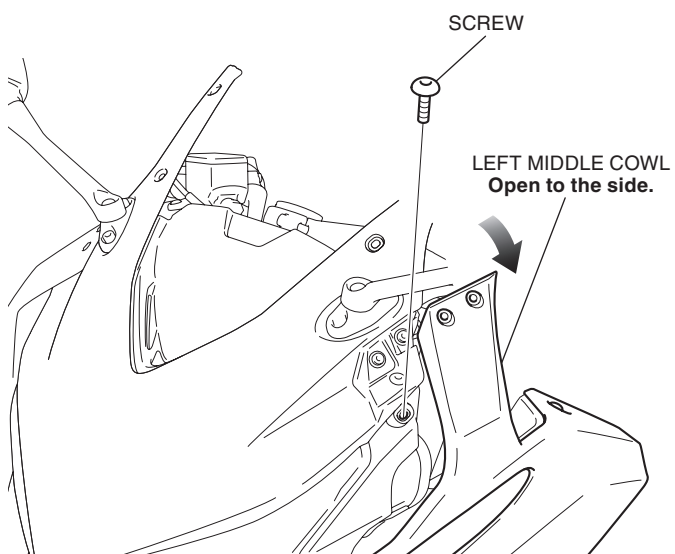

5. Remove the clip as shown.

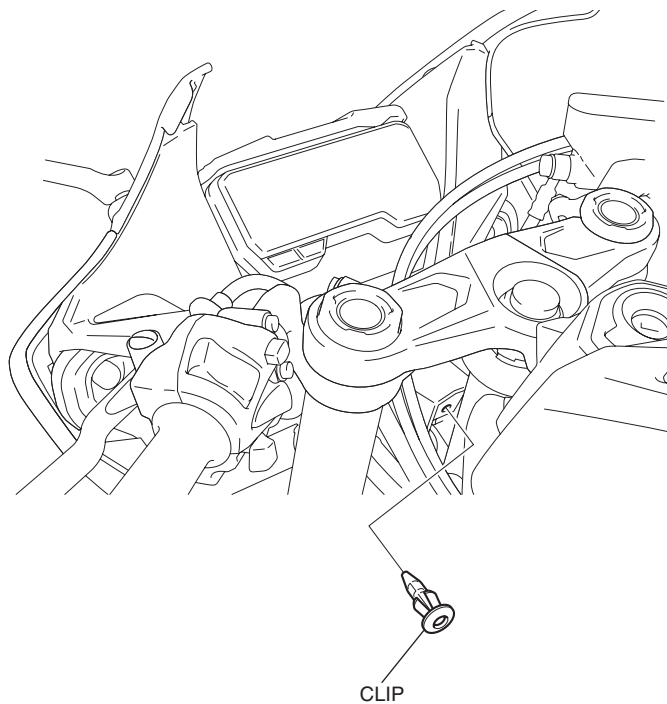

6. Remove the meter as shown.

METER  
Disconnect the connector.

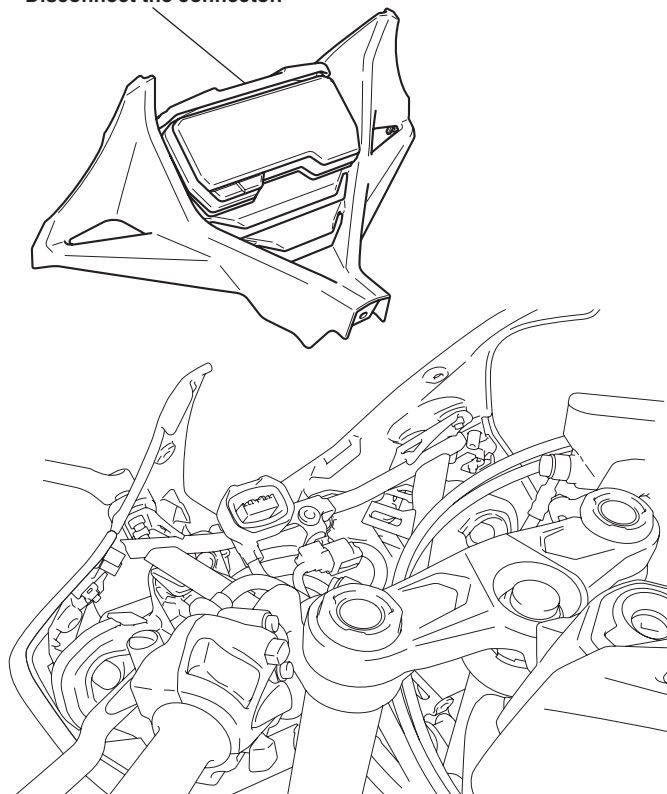

7. Clean the surface of the area shown using an isopropyl alcohol.

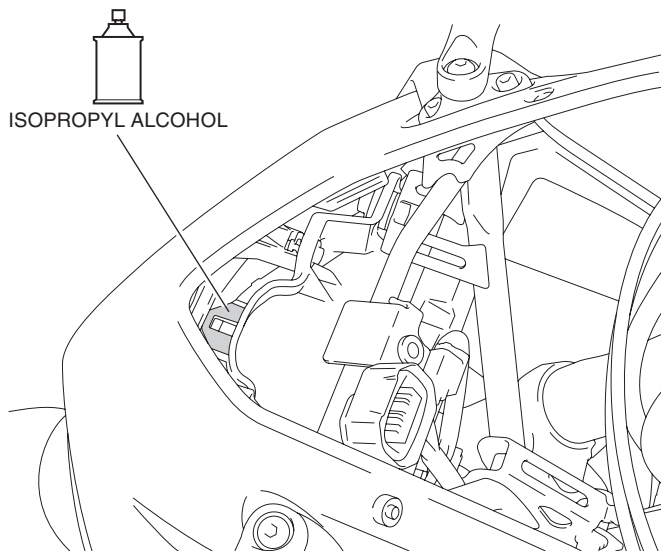

8. Apply primer to the position shown.
- After applying, allow the primer to dry for at least 10 minutes.

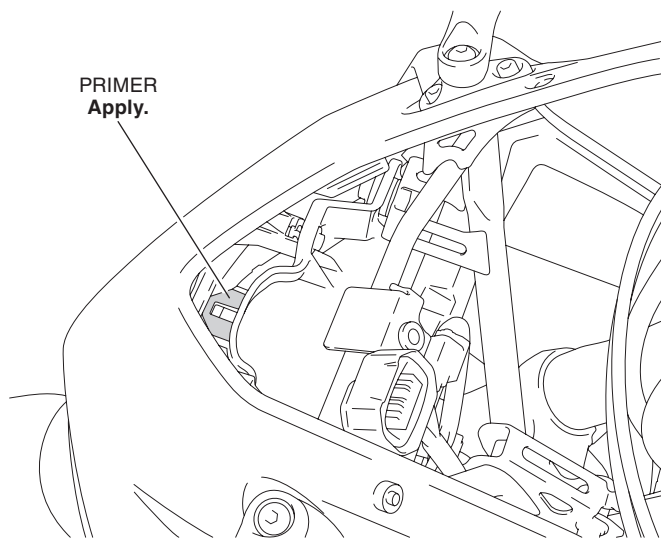

9. Attach the aluminium tape as shown.

ALUMINIUM TAPE  
Remove the adhesive  
backing before attaching.

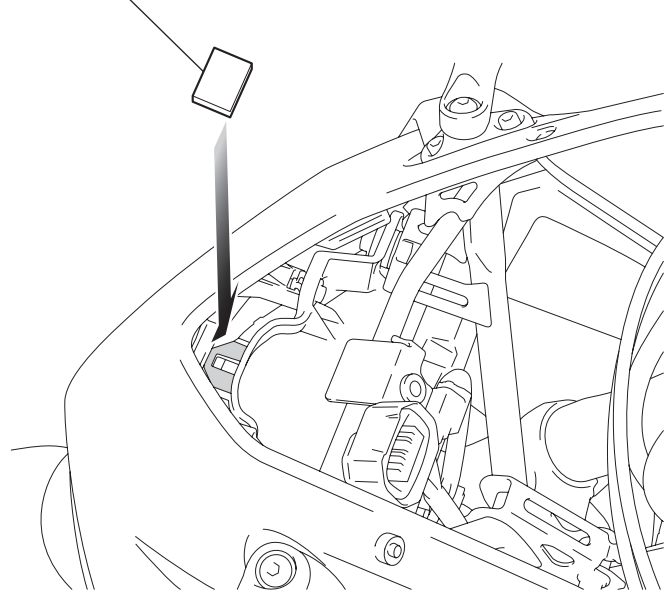

10. Install the meter in the reverse order of removal.  
11. Install the right and left middle cowl in the reverse order of removal.  
12. Remove the well nuts as shown.

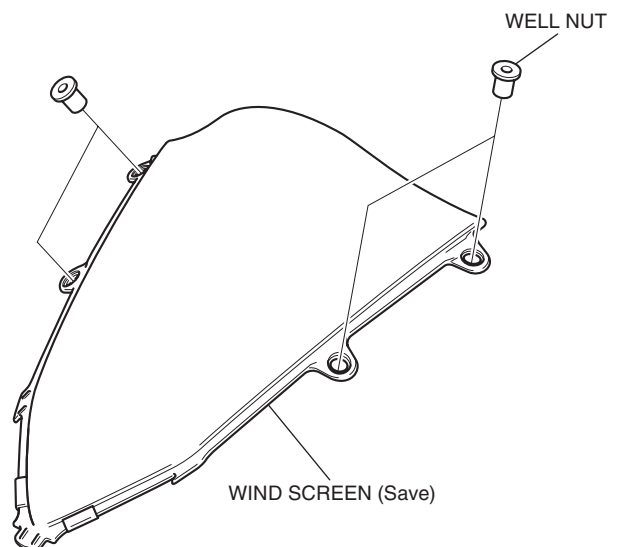

13. Install the well nuts as shown.

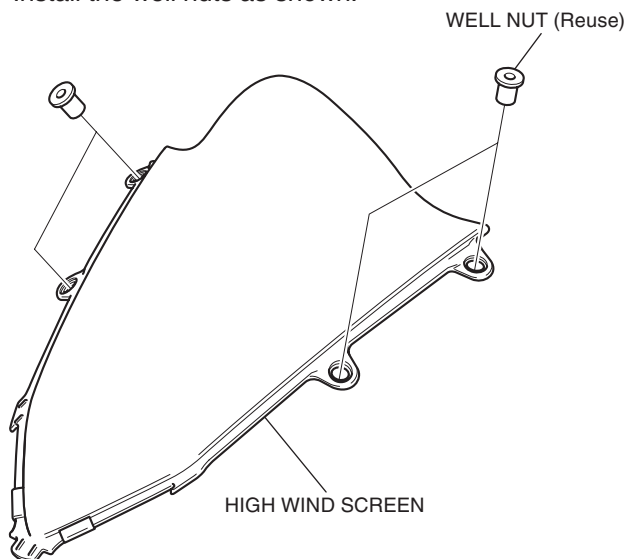

14. Install the high wind screen as shown.

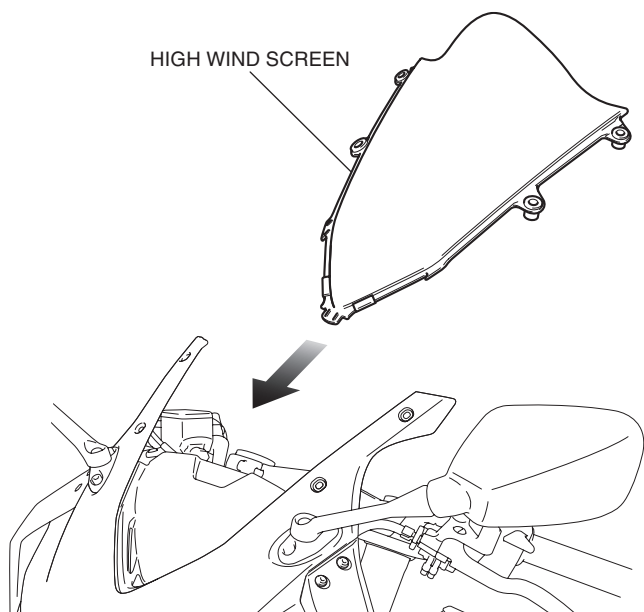

15. Install the parts as shown.

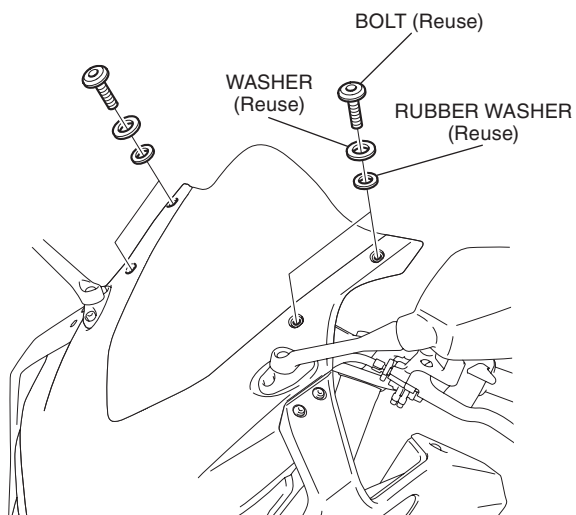

16. Attach the label in the position shown.

